

Unified Threat Management

# NETASQ Multifunction Firewall U Series

NETASQ U30



NETASQ U70

**High Performance to Secure your Future**

P2 . Client testimonials

P3 . Appliance features

P4 . Technical specifications

The U30 and U70 models in the U Series are the ideal security solutions for SMEs or large subsidiaries. The performance and level of security of the U Series make the U30 and U70 appliances efficient and durable solutions.

## Top-of-the-range performance

The U30 and U70 appliances are the fruit of years of research and development, which have resulted in the total synergy of the hardware and software architectures (the development of security features at the heart of the network operating system). As such, they are capable of unequalled performance in terms of intrusion prevention. Embedded also on each U30 and U70 appliance is a VPN ASIC, which ensures the secure, high-throughput interconnection of sites.

*Find out the technical specifications on pages 3 and 4*

## Guaranteeing your security

The core of the NETASQ Firewall U Series centers around its proprietary system that embeds firewall features and real-time intrusion prevention. The NETASQ engine analyzes network protocols and the applications in order to detect and block threats, and thanks to numerous behavioral analyses and different targeted signature databases (depending on the context), it delivers a very high level of security by dramatically reducing the risk of false alarms.

*More information is available on <http://asq.netasq.com>*

## Simplicity is key

The U Series comes with an administration suite that also monitors your network environment in real time. These tools guide you step by step so that you not only save time but also fully adapt the protection to your needs. Furthermore, the suite allows you to generate automatic reports to take stock of changes in threats to your network.

### SECURITY



- Zero-day intrusion prevention
- Real-time risk management
- Antivirus > 500 000 virus signatures
- Antispam: up to 99% detection rate
- User based Firewall

### PERFORMANCE



U Series vs Competitors  
(A,B,C: products in the same price range)

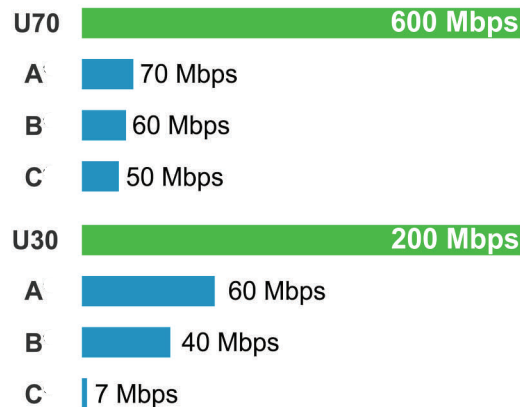

Firewall+IPS Throughput



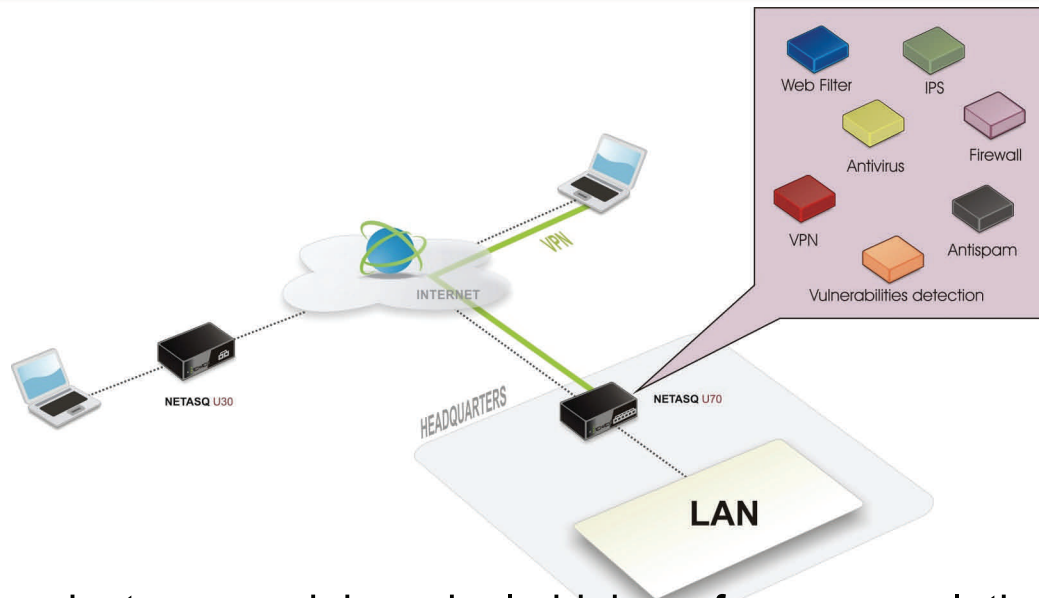

## 7 security products merged in a single high-performance solution

The U30 and U70 products are multi-function firewalls that combine many security modules. They offer SMEs the same level of security supplied to large corporate entities, while keeping in mind their budget restrictions. Automatic updates of IPS, antivirus, antispam and URL filter databases are a further guarantee of quality for administrators of SME networks, who typically have limited amounts of time to dedicate to managing their information systems.

*“NETASQ products have an excellent intrusion prevention system, no doubt about it. We mainly use the IPS as well as the classic features that one would find on any firewall. However, one of the aspects that appealed the most to us was the **simplicity and intuitiveness of the product**. We are assured that teams in the local economic departments can see to the watertight protection of their data on their own.”*

Fabien Marechal, Manager, information security, Ministry of the Economy, Industry and Employment (France)

<http://www.netasq.com/en/netasq/success-story.php>

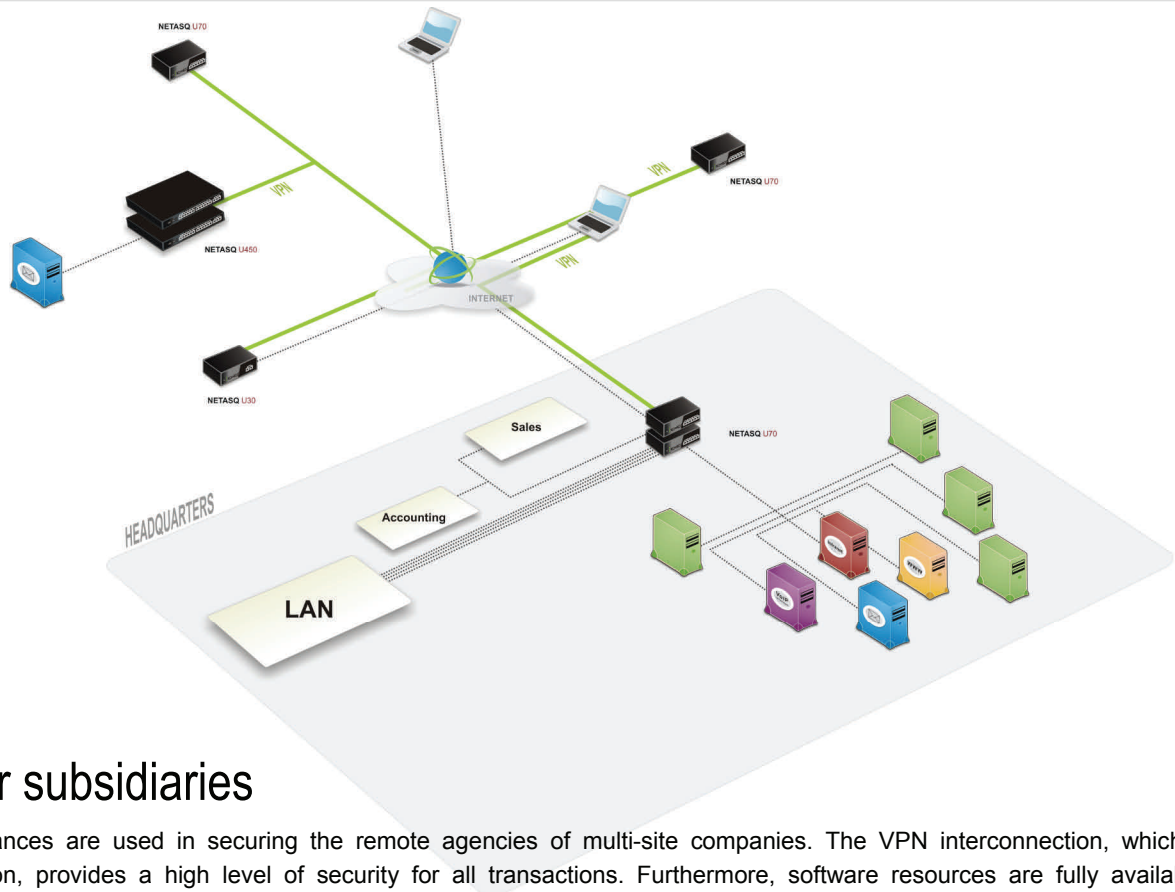

## Protect your subsidiaries

U30 and U70 appliances are used in securing the remote agencies of multi-site companies. The VPN interconnection, which uses hardware acceleration, provides a high level of security for all transactions. Furthermore, software resources are fully available for conducting all the security analyses necessary for the protection of the subsidiaries. NETASQ administration tools greatly facilitate the installation process, thus reducing considerably the length of the deployment phase.



MAIN CHARACTERISTICS *	U30	U70
Gigabit Interfaces (10/100/1000)	-	6
Fast Ethernet (10/100) Interfaces	2	-
Firewall + intrusion prevention throughput (Mbps)	200	600
Concurrent connections	50,000	100,000
New sessions per second	4,000	6,000
VPN ASIC	✓	✓
AES VPN performance (Mbps)	80	120
VPN Tunnels	50	100
Simultaneous SSL VPN clients	20	50
CAPACITIES*	U30	U70
Storage (GB)	-	-
Maximum number of filter rules	1,000	2,000
VLANs (802.1Q)	32	32
Simultaneous PPTP clients	48	48
WAN link redundancy	4	4
Dialup (PPPoE, PPTP, L2TP, PPP)	4	4
HARDWARE SPECIFICATIONS	U30	U70
Racking	1U (half width)	1U (half width)
Height x Width x Depth (mm)	44.4 x 216 x 178	44.4 x 216 x 178
Product weight / packed weight	1.5 kg (3.3 lb) / 2.3 kg (5.1 lb)	1.6 kg (3.6 lb) / 2.4 kg (5.3 lb)
Power supply (AC)	230V 20W 0.2A (external)	230V 37W 0.36A (external)
Maximum thermal dissipation (BTU per hour)	69	126
Cooling subsystem	-	1
ENVIRONMENT	U30	U70
Operational temperature	5° to 40°C (51° to 104°F)	5° to 40°C (51° to 104°F)
Storage temperature	-30° to 65°C (-22° to 149°F)	-30° to 65°C (-22° to 149°F)
Humidity	20% to 90% (without condensation)	20% to 90% (without condensation)
IPS — APPLICATION BASED FIREWALL	U30	U70
Application based Firewall - Real-time IPS (ASQ engine)	✓	✓
Protocol detection, analysis and normalization	✓	✓
Behavioral and statistical protection	✓	✓
Contextual signature protection	✓	✓
Risk management — SEISMO	optional	optional
MULTIFUNCTION FIREWALL — UTM	U30	U70
SMTP, POP3, HTTP, FTP proxies	✓	✓
Embedded antivirus	✓	✓
Kaspersky antivirus	optional	optional
Antispyware	✓	✓
Reputation-based Antispam (DNS RBL)	✓	✓
Heuristic Antispam analyses	✓	✓
URL Filtering (15 categories)	✓	✓
BUSINESS CONTINUITY	U30	U70
High Availability Active-Passive	-	✓
Synchronization of configurations	-	✓
Session recovery	-	✓
Hardware failure detection	-	✓

\*Figures may vary according to the configuration, deployment conditions and type of traffic

Note: For certain features, updates of the software version might be necessary

NETWORK — ROUTING — QUALITY OF SERVICE	U30	U70
Transparent, routed, hybrid modes	✓	✓
Address translation (NAT,PAT, split)	✓	✓
Static routing — Policy Based Routing	✓	✓
Dynamic routing	RIP, BGP, OSPF	RIP, BGP, OSPF
Bandwidth guarantee/limitation	✓	✓
Priority-based bandwidth management	✓	✓
DiffServ filtering/markings	✓	✓
<b>IPSEC VPN</b>	<b>U30</b>	<b>U70</b>
DES/3DES, AES, Blowfish	✓	✓
MD-5, SHA-1, SHA-2	✓	✓
IPSec NAT Traversal	✓	✓
Dead Peer Detection (DPD)	✓	✓
Hub & Spoke	✓	✓
<b>USER BASED FIREWALL</b>	<b>U30</b>	<b>U70</b>
Internal database (LDAP)	✓	✓
Third-party authentication	LDAP, Active Directory, Radius, NTLM	LDAP, Active Directory, Radius, NTLM
Transparent authentication Microsoft SPNEGO — SSL Certificate	✓	✓

### IPS — APPLICATION BASED FIREWALL

- Real-time policy compliance checker
- Policy scheduling
- Automatic quarantining in case of attacks
- Protection from flooding attacks
- Protection from data evasion
- Advanced management of fragmentation
- Protection from SQL injections
- Protection from Cross Site Scripting (XSS)
- Trojan horse detection
- Protection from session hijacks
- Dedicated application analysis (plugins) : IP, TCP, UDP, HTTP, FTP, SIP, RTP/RTCP, H323, DNS, SMTP, POP3, IMAP4, NNTP, SSL, MGCP, Edonkey, SSH, Telnet ...

### Management

- Role administration
- NETASQ UNIFIED MANAGER
- NETASQ REAL-TIME MONITOR
- NETASQ EVENT REPORTER
- ssh v2

### Monitoring — Reporting

- Logging to Syslog servers (max 3)
- E-mail alerts
- Automatic report generation
- SNMP v1, v2, v3 (DES, AES) agent

### Network services

- DHCP client and server
- NTP client
- DNS cache proxy

### Options

- Kaspersky: Antivirus, Antispyware, Antispam
- NETASQ SEISMO: Risk management

### Certifications

NETASQ products have been awarded Level EAL4+ international common criteria V3.1 certification (international standard ISO 15408 and ISO 18045). NETASQ is furthermore the first firewall vendor to have obtained a backing from French authorities on the encryption services (VPN) that its products offer.



NETASQ U30



NETASQ U70

### NETASQ HEADQUARTERS

3, rue Archimède  
59650 VILLENEUVE D'ASCQ  
  
Tel +33 3 20 61 96 30 . Fax +33 3 20 61 96 39  
contact@netasq.com

### SALES CONTACTS

BENELUX & NORDICS . Breda . +31 76 8883022 . benelux@netasq.com  
FRANCE . Paris . +33 1 46 21 82 30 . france@netasq.com  
DACH . München . +49 172 8504473 . dach@netasq.com  
IBERIA . Madrid . +34 91 761 21 76 . iberia@netasq.com  
ITALY . Milano . +39 02 3809 3751 . italia@netasq.com  
UK . London . +44 191 2574802 . uk@netasq.com  
EMEA . emea@netasq.com

